



MISSILE WEAPONS CONSTRUCTION MANUAL

AS ADOPTED JULY 2001
UPDATED JANUARY 2002, MARCH 2003

© 2002, 2003 The Adrian Empire Inc., all rights reserved.
“Adria” is a registered trade name of the Adrian Empire, Inc.
Anyone is welcome to point out any error or omission that they may find.

Imperial Minister of Archery archery@adrianempire.org
Empress empress@adrianempire.org
Emperor emperor@adrianempire.org

TABLE OF CONTENTS

PREFACE	3
COMBAT ARROWS	3
A. Size	3
B. Arrow Heads.....	3
C. A Reminder.....	4
D. Safety.....	4
E. Specifications	4
F. Materials.....	5
G. Combat Arrow Construction	7
H. Combat Arrow Finishing.....	9
SIEGE WEAPONS	10
A. Siege Weapons Construction	10
B. Ammunition Construction	10
APPENDIX A: USING CAMPING MATS AS CIRCLES	12

PREFACE

This is the authorized construction manual for combat arrows **and other missile weapons**, to be used by the Ministers of Archery and populace within the Adrian Empire. The original manual was created by Second Skin Designs for the use in the LARP organization. <http://www.here-be-dragons.demon.uk> It was used by permission, re-written and revised for use in the Adrian Empire.

Archery was authorized in Adria in 1999, when this manual was first published. Since that time, it has undergone clarification and expansion, the most extensive in 2002. In February, 2003, missile weapons were added to the manual, requiring an extensive rewrite and reorganization to include all aspects of missile weapon combat. **There were no changes to existing rules, only clarifications. All additions pertain to missile weapons.**

COMBAT ARROWS

What do we need from an arrow to be used in Adrian combat?

- Most importantly, we need an arrow design which is as safe and durable as possible
- We do not want to compromise the accuracy of the arrow too greatly with over bulky head designs
- We want an arrow that is as accurate as we can possibly shoot
- It must be fairly cost-effective

The cost-effectiveness is important because arrows get broken (usually under foot in combat situations). Ready-made arrows get expensive. They are fairly time-consuming to make, and therefore sell for a high price from retailers. Many people want to make their own arrows anyway, and many others have to for financial reasons. If you can make your own safely and correctly, it will only cost you the price of the materials, and you will be in a position to make new ones whenever you want (and it can be fun!)

A. Size

In any live combat environment, there is only one safe size for an arrow point: large enough to prevent a hit in the eye from hurting that most-precious part of the body. The most appropriate size we have found is around 50mm (2" inches) in diameter. If the head is any larger than that, it simply slows down the arrow and spoils its accuracy - any smaller and the head becomes a dangerous size for eyes. For this reason, no head diameters less than 40mm.

B. Arrow Heads

The head of an Adrian combat arrow must be soft enough for a close range shot not to damage delicate areas of the body (in case of unforeseen accidents). It must be robust, long-lasting, and eliminate all possibilities of the arrow shaft punching through the foam to the outside world. If this were to happen, the possibility of someone being impaled by a combat arrow would be very real indeed! This must be avoided at all cost as the future of the hobby depends upon it.

The head of an Adrian combat arrow must be soft enough for a close range shot not to damage delicate areas of the body (in case of unforeseen accidents). It must be robust, long-lasting, and eliminate all possibilities of the arrow shaft punching through the foam to the outside world. If this were to happen, the possibility of someone being impaled by a combat arrow would be very real indeed! This must be avoided at all cost as the future of the hobby depends upon it.

For the sake of this guide, we will call the foam point on the end of the arrow that we are going to make the head. This way nobody can get too confused about sharp points, foam points etc!

C. A Reminder

Nothing in this world is guaranteed. Bows and arrows are killing tools and must be treated with the utmost seriousness and care. Once you let that arrow fly, it's out of your hands. No matter how good you are, fate will play its part.

D. Safety

The marshals will be tasked with the responsibility to weapons checks to ensure the safety of the arrows. Any cracked or nicked arrows should be removed from the field (they create stress raisers, which will increase the likelihood of breakage).

Furthermore, the marshal is responsible for checking bows for their draw weight. This is usually found written somewhere on the bow. The marshal should not allow a bow with a draw weight heavier than 35lbs at 28". These arrows have been tested in a safe environment with a bow that had a 45lbs draw and although they were still safe, hit pretty solidly. **Safety first!**

E. Specifications

1. Minimum Specifications

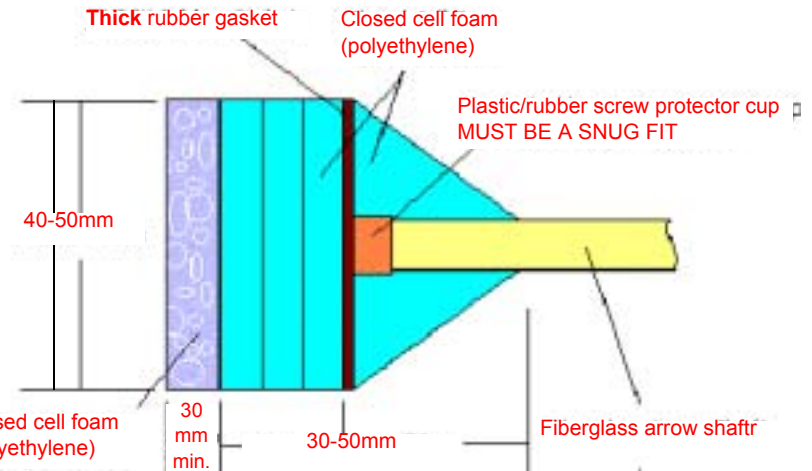

2. Recommended Specifications

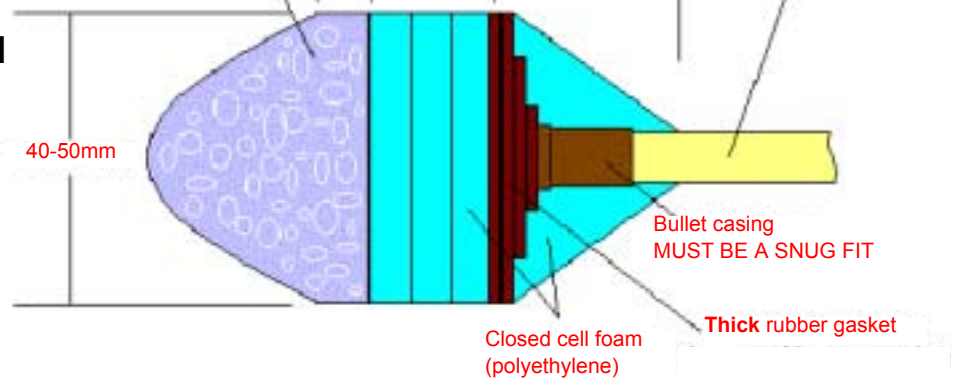

F. Materials

All of the materials are discussed in detail below, but are recapped here for reference.

<i>Arrow Part</i>	<i>Material</i>	<i>Comments</i>	<i>Availability</i>	<i>Approx. Cost</i>
Shaft	Fiberglass	Commonly referred to as Thunderglass. Must be fiberglass.	Any archery store	\$9.00/dozen (bare shafts) or \$2.00/arrow
Head	Polyethylene foam	25mm thick (or 3 layers of 10mm camping mat foam). Must be polyethylene.	Foam plastics manufacturers or camping stores like Big 5 or REI	\$7.00 to \$8.00
Tip	Upholstery foam/ sponge	About 30mm thick	Most furniture stores, shipping or other place where packing material can be found.	\$2.00 to \$5.00 a block
Blunt cap	Rubber	Recommended: The caps used to cover the ends of "Closet Maid" closet racks	Do-it-yourself stores	\$3.00 for about 100 to 160 caps
	Plastic	Ideal because they don't add any weight to the arrow.		
	Bullet cap (shell cases)	7mm shell case should be perfect	Sporting goods or gun supply stores	\$10.00/100
Tip divider (between the arrow head and the arrow tip)	Thick rubber	The key is THICK rubber. Plumber's gaskets provide the best strength.	Tire shops (for pain rubber). Do-It-Yourself stores (for plumber's rubber gaskets): get the thicker of the available gaskets.	\$.78 per 6"x6" sheet
Finishing	Liquid latex rubber	Do not use water-based adhesives as they will fall apart in climatic (damp) conditions.	Do-it-yourself stores (sold in cans to dip tool handles or as liquid electrical tape)	\$5.00/4-oz can
	Carpet tape	Acceptable substitute for latex rubber	Do-it-yourself stores or carpet stores.	\$5.00/roll
	Fiberglass packing tape	MUST have the threads that run through them (for strength). Much preferred over carpet tape if at all possible	Places like Wal-Mart, craft stores, or shipping places.	\$5.00/roll

1. Fiberglass Arrow Shafts

The arrow shafts MUST be made of fiberglass - NO EXCEPTIONS!

The arrow shafts can be made or bought at a local archery store. If you buy whole arrows be sure to cut the arrowhead off. Be sure that the end of the shaft is flat with no sharp edges to it. This manual is written with the minimum specifications in mind which are sufficiently safe. However, maximum efficiency is encouraged and are included here. I encourage you to build them to the maximum specifications.

2. Foam

The main foam MUST be made of polyethylene - NO EXCEPTIONS!

There are two (2) different types of foam used to construct the arrows. The first type is known as polyethylene foam (a very common material in camping mats). It is rubbery in texture. This foam is the main bulk of our arrow as it is medium-soft, resilient, easy-to-carve and hard-wearing. If you can find it, the ideal thickness is 25mm sheets. Note - camping mats made of polyethylene are usually 10mm thick.

Upholstery foam is used for the tip end of the arrow head. This should be 30mm thick (more if desired). The cone part of an eggshell crate is a good choice because the cone shaping is already done (a cone shape is best for arrow flight). This foam is not essential, but helps greatly to act as a buffer on impact.

3. Blunt Cap

Whatever type of cap is used, it must fit snugly. Caps that are too big for the arrow shaft can affect arrow's characteristics and could make them dangerous.

The cap helps to spread the load exerted on impact against the inside face of the foam. It also eliminates any potential sharp edges on the end of the shaft and increases the gluing area of the foam. Plastic caps are ideal as they don't add any weight to the arrow, so it maintains its flight characteristics. There is one advantage to using rubber blunts: when the foam is built around a rubber blunt, the likelihood of anyone be impaled by that arrow, if the foam were to fall apart is very slight indeed. It is better to get a bruise than have vital organs punctured. For maximum efficiency, a bullet cap is the best.

4. Rubber Divider

The divider MUST be made of rubber - NO EXCEPTIONS!

Plumbers rubber gaskets are the only real choice here as it provides the greatest strength. Carpet tape, duct tape, cloth foam or leather are not acceptable as a replacement for thick rubber. They are simply not strong enough. Do not use a piece of metal or a coin. These materials are too solid (they have no "give") and could cause the fiberglass shaft to fracture. Do not use plastic as it is likely to crack.

5. Liquid Latex Rubber (Finishing Option 1)

This helps to seal the arrow head, and make it more presentable for use. Black latex is preferred because it covers better and is less intrusive in color than other color choices.

6. Packing Tape (Finishing Option 2)

An acceptable alternative to the liquid latex rubber is fiberglass packing tape. The tape MUST have the threads that run through them for strength. This is much preferred over carpet tape if at all possible. If carpet tape must be used, it must also have the threads running through them for strength.

7. Tools

Assemble all the tools needed before starting construction:

- Hot glue gun (with glue)
- Contact adhesive (spray adhesive is preferred)
- Ball point pen (for marking shapes and sizes on the foam)
- Steel ruler (steel so that you don't shave the edges if you use the craft knife)
- Craft knife (with an extendable blade)
- Knife sharpener, or extra blades (the foam dulls the blade very quickly)
- Safety glasses (always recommended)
- Paintbrush (for painting the liquid latex rubber, if used)
- Talcum powder (for preventing the liquid latex rubber from sticking)

G. Combat Arrow Construction

1. Attach the blunt cap to the arrow shaft.

Make sure the cap is a tight fit. Glue the cap onto the end of the shaft, making sure it is secure and fully pushed onto the shaft.

DO NOT BUILD THE FOAM HEADS AROUND AN UNGLUED BLUNT. If the arrowhead is removable by hand, it can be removed during flight!



2. Cut the foam into blocks.

This method is for 25mm thick polyethylene foam. Construction using 10mm foam (camping mats) are described in [Appendix A](#).

Cut out three blocks: 50mm x 50mm x 25mm for each arrow. Set aside one block (it will be used for the padded head).

On each of the two blocks that will be used for the sides, cut a v-shaped groove the length of the block. This will be for the arrow shaft, so check the size of the groove for fit.

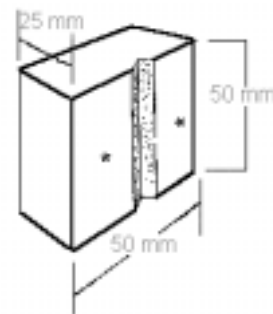

As an alternative, you can cut circles, instead of blocks. See [Appendix A](#).

3. Hot glue the blocks together.

Spray contact adhesive on the grooved sides of the two side blocks. Let the glue dry.

Using the hot glue gun, lay down a line of glue in the groove of one side block. Place the arrow shaft into the groove. Make sure the blunt tip is flush with the top of the foam block. Lay down a line of glue in the other side block. Firmly place the blocks together with the shaft in the middle.

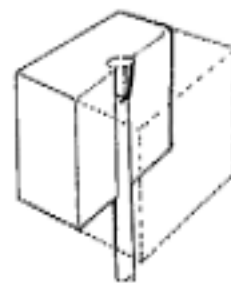

DO NOT USE HOT GLUE TO BOND THE BLOCKS TOGETHER. The joint will not be as accurate and it is extremely difficult to carve through.

4. Trim the block into a cylinder.

Slice off the corners of the this foam block. Cut off the corners of the new "octagon" you just created. This leaves an approximation of a cylinder. Trim the arrow head into a more formed cylinder shape.

Trim carefully and only a small amount at a time.

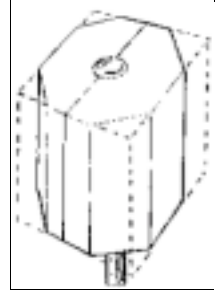

5. Trim the cylinder into a cone shape.

Still very carefully slicing only small amounts of foam, trim the cylinder into a tapered cone shape.

DO NOT CUT THE SHAFT. This will create a stress raiser, weaken the head, and therefore it will be more likely to break off during use. For obvious reason this can be VERY dangerous!

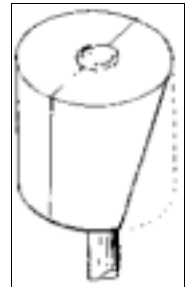

6. Hot glue the rubber divider onto the foam block.

A thick rubber divider must be used to prevent the shaft from forcing its way through the foam during impact.

Cut out a 50mm circle of thick rubber. Hot glue this to the top of the cone, centered on the shaft. Use as many layers as you are comfortable with, just don't skip this step! Three layers has proven to be near-perfect. It provides maximum protection without over weighting the head.

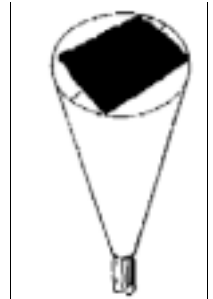

7. Fasten the third foam block to the head.

Using contact adhesive, glue the last 50mm block to the end of the cone.

Again, do not use hot glue for this step. It is near impossible to carve through it.

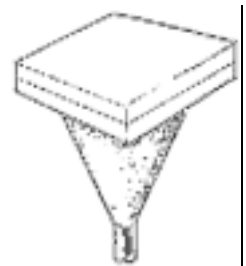

8. Trim the top of the cone.

Carefully trim the foam block, following the shape of the cone.

Do not get the knife at an awkward angle, otherwise the shape will be uneven, affecting the arrow's flight.

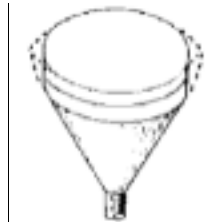

9. Attach the tip of the arrow.

This foam is not essential, but helps greatly to act as a buffer upon impact. Cut a 50mm square of upholstery sponge/foam, at least 10mm thick. Use contact adhesive to glue this tip onto this end of the head. Trim the square to flow with the cylindrical shape of the arrowhead. As an alternative, you can use eggshell foam. One "cone" is about the right size. Trim to fit the top of the head and fasten as described above.

H. Combat Arrow Finishing

Finishing the arrowhead adds to the life of the arrow, and provides a much better-looking arrow. There are three acceptable methods to finish the arrowheads: Liquid latex rubber, carpet tape or fiberglass packing tape (with threads in it).

1. Liquid Latex Rubber

Using a paintbrush, coat the head with two layers of liquid latex rubber. This helps to seal the head, and make it more presentable for use.

Let the first coat dry before applying the second coat. Paint onto the arrow shaft about 10mm. Two layers is enough to create the seal and will last for as long as the arrow will. Any more will just waste your time and add needless weight to the arrow.

Stipple the second coat with the brush (or a piece of sponge) to create a cast metal image and eliminate brush strokes. You may also dry brush the latex with silver acrylic paint to add a metal effect when the latex is dry. If you don't use paint, dust the heads with talcum powder to prevent them from sticking together - fresh dry latex rubber acts a lot like contact adhesive.

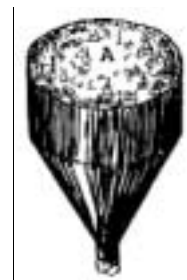

DO NOT latex the upholstery sponge foam end of the arrowhead. It does not allow air to escape on impact which negates the effectiveness of the sponge buffer.

2. Carpet or Packing Tape

If liquid latex rubber is not available, carpet or packing tape may be used.

Cut two strips to wrap around the arrow and slightly overlap. **DO NOT** wrap the tape level with the sponge tip. This tends to stiffen the end. Set it back a few millimeters.

Holding the arrow upright, slice the tape from the edge all the way down to the end of the cone, creating a fringe. Take a piece of fringe at a time and press down onto the cone and just onto the arrow shaft.

Wrap the bulk area (not the cone area) with another layer of tape to prevent the first layer from flaying off during use.

If using fiberglass packing tape (with threads in it): use 1/4" wide strips. Press them down vertically onto the head, and just onto the shaft. Remember not to set it flush with the top of the arrowhead (very similar to the fringe procedure stated above.) When done, would wrap the bulk area (not the cone area) with another layer of packing tape to prevent the first layer from flaying off during use.

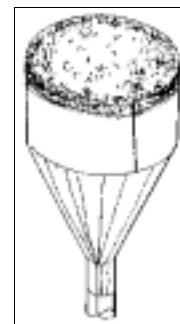
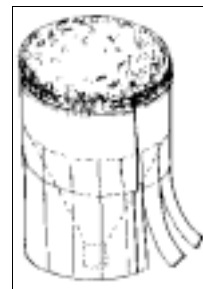

SIEGE WEAPONS

This section details the requirements for construction of siege weapons for use in the Adrian Empire.

These requirements are intended to produce a siege weapon that is reasonable authentic as well as safe to use in combat. Siege weapons may be built for a specific type of combat (Shinai through Armored), or may be designed for use in all types of combat so long as it follows the rules set out for force and range.

A. SIEGE WEAPONS CONSTRUCTION

These are rules that apply to all siege weapons regardless of type of combat and style of weapon. Siege weapons must:

- have a base that is stable enough to prevent the weapon from tipping over when firing
- not use compressed gasses or ignited propellants of any kind

1. Catapult/Trebuchet/Mangonel/Onager

Must have a mechanism for firing that can be triggered from at least 3 feet away. This does not apply if the weapon is man-powered.

- If pine or similar soft wood is used for a throwing arm for a catapult or trebuchet, it must be reinforced with steel, or secured against breakage with a minimum of glue-soaked sisal or jute cord wrapping (two-inch (2") wraps every six (6) inches) over a section of rope glued to the arm along the full length of the arm. This will keep the arm from leaving the weapon should it break.
- Can have a maximum range of 80 yards. This is to prevent dangerous amounts of force when targeting an object at extreme close range. Weapons capable of longer range must be adjustable down to this maximum.

2. Ballista

Bowstrings must be made of non-metallic materials.

- Must have a mechanical release mechanism though they may be cocked by hand
- Limbs made of laminated or layered wood must be secured along the length of the limb with leather or chord banding at at least 2 positions on each limb.
- Can have a maximum range of 80 yards for Armored combat and a maximum range of 50 yards for Shinai and Renaissance combat. This is to prevent dangerous amounts of force when targeting an object at extreme close range. Ballistas capable of longer range must be adjustable down to this maximum.

B. Ammunition Construction

1. Large Rocks

Shinai/Renaissance combat:

- Shall not weigh more than one-half pound
- Shall not be smaller than five (5) inches in diameter
- May be hollow rubber balls or constructed of foam covered with duct or fiber-reinforced tape

Armored combat:

- Shall not weigh more than one pound
- Shall not be smaller than six and one-half (6-1/2) inches in diameter
- May be constructed of low density foam, or foam core covered with terri-cloth or padded fabric, held together with duct or fiber-reinforced tape

2. Ballista Bolts

Bolts shall be made of golf club tube shafts with a tennis ball taped onto the tube with no less than 2 layers of duct or fiber-reinforced tape (one layer completely covering the ball and four inches of shaft, followed by a second layer). PVC pipe is not approved as it is not shatter resistant.

- The tubes may be reinforced with medium density foam (e.g. pipe insulation) to make them more resistant to crushing damage.
- "Fletchings" may be added so long as they are not of a rigid material or have sharp edges. Edges of plastic fletchings may be covered with duct tape to dull them.

Shinai/Renaissance combat:

- The overall length of the bolt must be no less than 24 inches and no more than 36 inches.
- The overall weight of the bolt must be no more than 1/2 pound.

Armored combat:

- The overall length of the bolt must be no less than 24 inches and no more than 48 inches.
- The overall weight of the bolt must be no more than 1 pound.

Some measure must be taken to cover thenock end of the bolt to prevent splitting and having exposed sharp edges. Bolts may have a short (less than 2" long) non-hardwood, non-metallic insert in the knock end to prevent that end from being damaged by the bowstring. 1-1/4" diameter rattan works well for this purpose.

3. "Grape" Shot

Tennis or handball balls disguised with tape or paint must be used and must remain hollow

- May be used for all types of combat
- Up to 4 shot may be fired at once.
- Each shot has the same effect as a combat arrow (see [Adrian Combat Manual](#))

APPENDIX A: USING CAMPING MATS AS CIRCLES

1. Cut the camping mat into circles.

Use a 2-inch cookie cutter (or other template) to trace a circle onto a 10mm thick camping mat. Cut the camping mat into 9 disks, each one approximately 50mm in diameter. Do not make the circles smaller than 40mm in diameter – there's not enough surface area to disperse the impact.



2. Fasten the circles together.

Using contact adhesive, glue the circles together to create 2 stacks, 3 circles high, and 6 circles high.

When using contact adhesive properly, the disks glue together so well that it's almost as if they were one solid piece.

Set aside the 3-stack to use later.

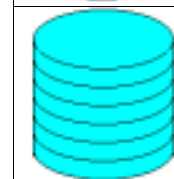

3. Cut the 6-stack in half.

Carefully cut the cylinder in half down its long axis. This is where the arrow shaft will fit, so be very careful in your cut.

If the cut is uneven, it could ruin the flight path.

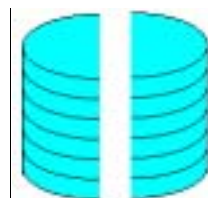

4. Cut a groove for the shaft.

Cut a v-groove the length of the block for the arrow shaft. Be sure the groove is only half as deep as the arrow shaft.

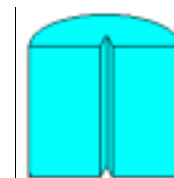

5. Hot glue the halves back together.

Spray contact adhesive on the grooved sides of the two side blocks. Let the glue dry. Using the hot glue gun, lay down a line of glue in the groove of one half-stack. Place the arrow shaft into the groove, making sure the blunted tip is flush with the top of the foam block. Lay down a line of glue in the other half-stack. Firmly place the blocks together (with the shaft in the middle).

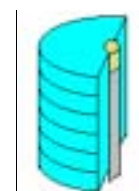

DO NOT USE HOT GLUE TO BOND THE BLOCKS TOGETHER. The joint will not be as accurate and it is extremely difficult to carve through.

6. Go back to Construction Step 5.

Finish making the arrow heads according to the construction directions starting at **Step 5**. **Trim the cylinder into a cone shape.**

